

PRODUCT TECHNICAL DATASHEET

MONOS4/220



CODE	BESCHRIJVING	STK/PALLET
MONOS4/220	Onomkeerbaar elektromechanische aandrijving met telescopische arm, 230V AC, voor draaihekken met vleugels tot 4 m snel.	50

TECHNISCHE SPECIFICATIES VAN HET PRODUCT

Stroomtoevoer	230V AC - 50Hz
Voeding motor	230V AC
Nominaal Vermogen	200W
Gebruik	30%
Motorstuwkracht	2400N
Werkings temperatuur	-20 C° +55 C°
Beschermingsfactor	IP43
Type motor	Onomkeerbaar
Cilindersnelheid	1,66 cm/s
Openingstijd	24 s
Slaglengte	400 mm
Thermische Veiligheid	150° C
Eindschakelaar	-
Encoder	-
Afmetingen (L x W x H)	1223 x 178 x 111
Productgewicht verpakt (Kg)	8,5
Aantal dozen per pallet	50

AFMETINGEN

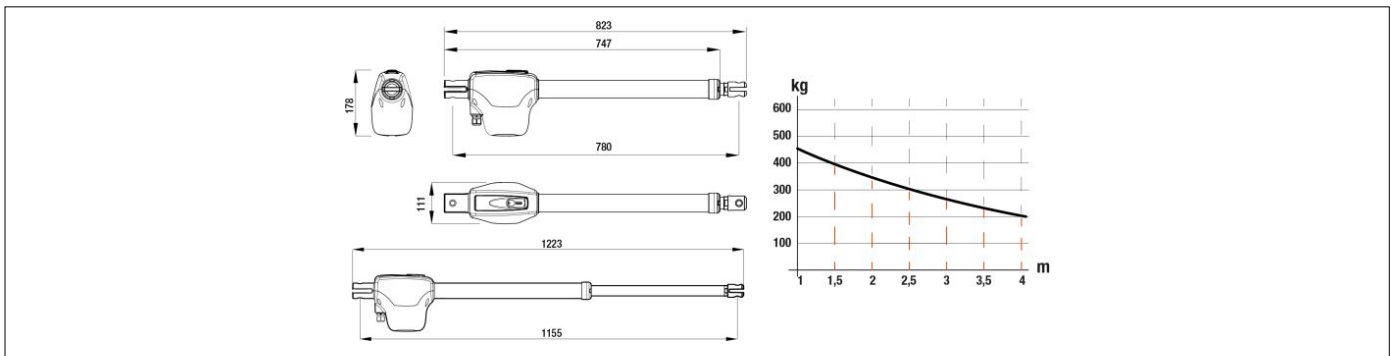

AFMETINGEN

OPSTELLING

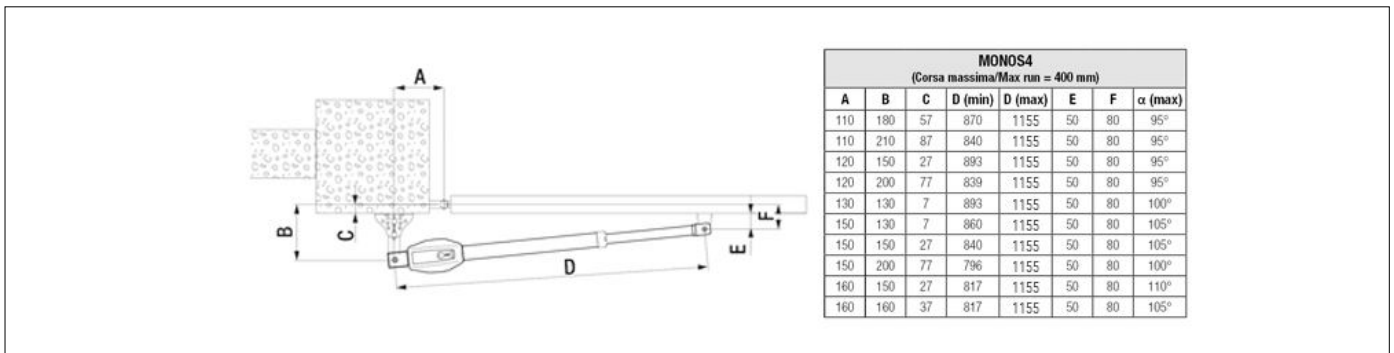

OPSTELLING VOOR STANDAARD INSTALLATIE

PRODUCTEN ACCESSOIRES

					
HT420 MONOS4-serie stuurpenafdekking.	KT204 Korte montagebeugel paal.	KT246 Set van schroefverstelbare korte achterste beugel en voorste beugel om te schroeven (MONOS4).	KT248 Frontbeugelsteun met M8-pennen voor MONOS4.	R99/C/001AL Uithangbord "Opent automatisch". Aluminium versie.	R99/C/001 Uithangbord "Automatic Opening".